

# Autonics

## THUMBWHEEL SWITCH SETTING TYPE TEMPERATURE CONTROLLER

### T3/T4 SERIES

#### INSTRUCTION MANUAL



Thank you for choosing our Autonics product. Please read the following safety considerations before use.

### Safety Considerations

- ※Please observe all safety considerations for safe and proper product operation to avoid hazards.
- ※Safety considerations are categorized as follows.
- Warning** Failure to follow these instructions may result in serious injury or death.
- Caution** Failure to follow these instructions may result in personal injury or product damage.
- ※The symbols used on the product and instruction manual represent the following
- ▲ symbol represents caution due to special circumstances in which hazards may occur.

### Warning

- Fail-safe device must be installed when using the unit with machinery that may cause serious injury or substantial economic loss.** (e.g. nuclear power control, medical equipment, ships, vehicles, railways, aircraft, combustion apparatus, safety equipment, crime/disaster prevention devices, etc.) Failure to follow this instruction may result in fire, personal injury, or economic loss.
- Install on a device panel to use.** Failure to follow this instruction may result in electric shock or fire.
- Do not connect, repair, or inspect the unit while connected to a power source.** Failure to follow this instruction may result in electric shock or fire.
- Check 'Connections' before wiring.** Failure to follow this instruction may result in fire.
- Do not disassemble or modify the unit.** Failure to follow this instruction may result in electric shock or fire.

### Caution

- When connecting the power input and relay output, use AWG 20(0.50mm<sup>2</sup>) cable or over and tighten the terminal screw with a tightening torque of 1.0N·m.** When connecting the sensor input and communication cable without dedicated cable, use AWG 28-16 cable and tighten the terminal screw with a tightening torque of 1.0N·m. Failure to follow this instruction may result in fire or malfunction due to contact failure.
- Use the unit within the rated specifications.** Failure to follow this instruction may result in fire or product damage.
- Use dry cloth to clean the unit, and do not use water or organic solvent.** Failure to follow this instruction may result in electric shock or fire.
- Do not use the unit in the place where flammable/explosive/corrosive gas, humidity, direct sunlight, radiant heat, vibration, impact, or salinity may be present.** Failure to follow this instruction may result in fire or explosion.
- Keep metal chip, dust, and wire residue from flowing into the unit.** Failure to follow this instruction may result in fire or product damage.

### Ordering Information

T	3	S	-	B	4	R	P	4	C	-	N	
Upgrade												
											N	New type
Unit												
											C	°C
											F	°F
Temperature range <sup>※1</sup>												
											0	-99 to 199°C, -99.9 to 199.9°C
											1	0 to 99.9°C
											2	0 to 200°C, 0 to 200.0°C
											4	0 to 400°C
											8	0 to 800°C/F
											A	0 to 999°C
											B	0 to 1200°C
											C	600 to 1600°C
Input type <sup>※3</sup>												
											P	DPT100Q
											J	J (IC)
											K	K (CA)
											R	R (PR)
Control output <sup>※2</sup>												
											R	Relay output
											S	SSR drive output
											C	Current output
Power supply												
											B	100-240VAC 50/60Hz
Alarm/Sub output <sup>※2</sup>												
											No mark	None
											A	Alarm output
											S	Sub output
											P	Dual setting output
Size												
											M	DIN W48×H48mm (8-pin plug type) <sup>※1</sup>
											S	DIN W72×H72mm
											H	DIN W48×H96mm
											L	DIN W96×H96mm
Digit												
											3	999 (3 digit)
											4	9999 (4 digit)
Item												
											T	Temperature Controller

※The above specifications are subject to change and some models may be discontinued without notice.  
 ※Be sure to follow cautions written in the instruction manual and the technical descriptions (catalog, homepage).

### Specifications

Series	T3S	T3H	T3HA	T3HS	T4M	T4MA	T4L	T4LA	T4LP	
Power supply	100-240VAC~ 50/60Hz									
Allowable voltage range	90 to 110% of rated voltage									
Power consumption	Max. 5VA									
Display method	7 segment (red) LED method									
Character size (W×H)	3.8×7.8mm 6.0×10.0mm			8.0×14.2mm						
Input type	RTD	DP100Q (Allowable line resistance max. 5Ω per a wire)							J (IC)	R (PR)
Display accuracy <sup>※1</sup>	TC	At room temperature (23°C ± 5°C); (PV ± 0.5% or ± 1°C, select the higher one) ± 1 digit							K (CA), J (IC)	K (CA), J (IC), R (PR)
Control output	Relay	OUT1: 250VAC~ 5A 1c, OUT2: 250VAC~ 2A 1c <sup>※2</sup>								
Alarm/Sub Dual setting output	Current	DC4-20mA (resistive load max. 500Ω)								
Control method	ON/OFF, Proportional control									
Hysteresis	F.S. 0.5%		F.S. 0.2 to 3% variable							
Proportional band	F.S. 3%		F.S. 1 to 10% variable							
Proportional cycle	20 sec.									
RESET range	F.S. -3 to 3% variable									
Relay Mechanical life cycle	Over 5,000,000 times									
Dielectric strength	OUT1: Over 100,000 times, OUT2: Over 200,000 times									
Vibration	2,000VAC 50/60Hz 1min. (between input terminal and power terminal)									
Insulation resistance	0.75mm amplitude at frequency of 10 to 55Hz (for 1 min.) in each X, Y, Z direction for 2 hours									
Noise	Square-wave noise by noise simulator (pulse width 1μs) ± 2kV R-phase and S-phase									
Memory retention	Approx. 10 years (when using non-volatile semiconductor memory type)									
Environment	Ambient temperature	-10 to 50°C, Storage: -20 to 60°C								
	Ambient humidity	35 to 85% RH, Storage: 35 to 85% RH								
Weight <sup>※3</sup>	Approx. 135g	Approx. 239g	Approx. 246g	Approx. 310g						
	(approx. 95g)	(approx. 176g)	(approx. 180g)	(approx. 222g)						

- ※1: In case of the T3S Series and the decimal point display models  
 At room temperature (23°C±5°C): (PV ± 0.5% or ± 2°C, select the higher one) ± 1 digit  
 Out of room temperature range: (PV ± 0.5% or ± 3°C, select the higher one) ± 1 digit
- ※2: Dual setting output of the T4LP is fixed as relay output and it is available as alarm output.
- ※3: The weight is with packaging and the weight in parentheses is only unit weight.
- ※Environment resistance is rated at no freezing or condensation.

### Unit Description

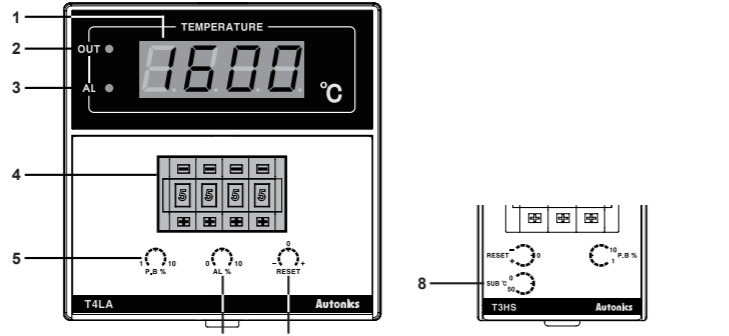

- Present temperature (PV) display**  
It displays present temperature.
- Control output (OUT) indicator**  
It turns ON when control output is ON.  
※In case of the T3S, the upper DOT of last digit flashes.
- Alarm output (AL) indicator**  
It turns ON when alarm output is ON. (only for alarm output model)  
In case of the sub output model (T3HS), the sub (SUB) indicator turns ON when sub output is ON.
- Set value (SV) thumbwheel switch**  
Switch for setting temperature.  
(-) button: Decreases number, (+) button: Increases number  
If the setting is out of the temperature range of temperature sensor, the present temperature (PV) display part flashes 5uE- and the present value in turn.  
※The models which temperature range is 0 (-99.9 to 199.9°C, -99 to 199°C) of temperature sensor DP100Q are only set 1~4 (-) (-).  
※The dual setting output model (T4LP) has two thumbwheel switches.  
LO SET (low set output) HI SET (high set output)
- Hysteresis/Proportional width volume switch (except T3S)**  
ON/OFF control: Setting for hysteresis. [Setting range] F.S. 0.2 to 3% (For T3S, F.S. 0.5% fixed)  
Proportional control: Setting for proportional width.  
[Setting range] F.S. 1 to 10% (For T3S, F.S. 3% fixed)  
Proportional cycle: 20 sec. fixed
- Alarm output value volume switch (only for alarm output model)**  
It sets alarm output value. [Setting range] F.S. 0 to 10%
- RESET volume switch**  
In case of proportional control, it sets offset. [Setting range] F.S. -3 to 3%
- Temperature setting of sub output volume switch (only for T3HS)**  
It sets temperature of the sub output. This output operates as deviation low-limit alarm based on the set sub-output temperature (SV). [Setting range] 0 to 50°C

※1: Socket (PG-08, PS-08(N)) is sold separately.  
 ※2: Output by Series

Series	T3S	T3H	T3HA	T3HS	T4M	T4MA	T4L	T4LA	T4LP
Control output	●	●	●	●	●	●	●	●	●
Control+ Alarm/Sub output	●	●	●	●	●	●	●	●	●
Dual setting output	●	●	●	●	●	●	●	●	●

※3: Input type and temperature range by Series

Input type	Model	T3S	T3H	T3HA	T3HS	T4M	T4MA	T4L	T4LA	T4LP
K (CA)	0 to 400°C	4	●	●	●	●	●	●	●	●
	0 to 800°C	8	●	●	●	●	●	●	●	●
	0 to 999°C	A	●	●	●	●	●	●	●	●
J (IC)	0 to 200°C	2	●	●	●	●	●	●	●	●
	0 to 400°C	4	●	●	●	●	●	●	●	●
	0 to 800°C	8	●	●	●	●	●	●	●	●
R (PR)	600 to 1600°C	F	●	●	●	●	●	●	●	●
	-99 to 199.9°C	0	●	●	●	●	●	●	●	●
	0 to 99.9°C	1	●	●	●	●	●	●	●	●
DPT 100Q	0 to 200.0°C	2	●	●	●	●	●	●	●	●
	0 to 200°C	2	●	●	●	●	●	●	●	●
	0 to 400°C	4	●	●	●	●	●	●	●	●

### Control Method (ON/OFF, proportional control) Setting

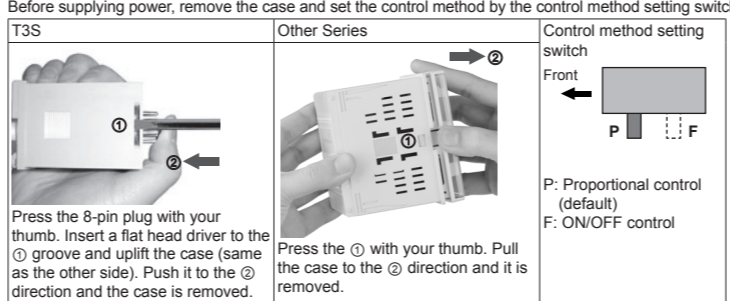

### Function

- Control method**  
  - 1) ON/OFF control**  
Comparing the present measured temperature and the set temperature, the temperature controller turns ON/OFF of the load power. Interval between ON and OFF of control output is set by the set hysteresis. When hysteresis of control output is too narrow, hunting (overshoot, chattering) may occur by external noise.  
[Setting range of Hysteresis] F.S. 0.2 to 3% (In case of T3S, F.S. 0.5% fixed)
  - 2) Proportional control**  
Proportional control has control output which is proportional to deviation from the present temperature to the set temperature in the proportional band to the set temperature.  
[Setting range of Proportional band] F.S. 1 to 10% (In case of T3S, F.S. 3% fixed)  
[Setting range of RESET] F.S. -3 to 3%

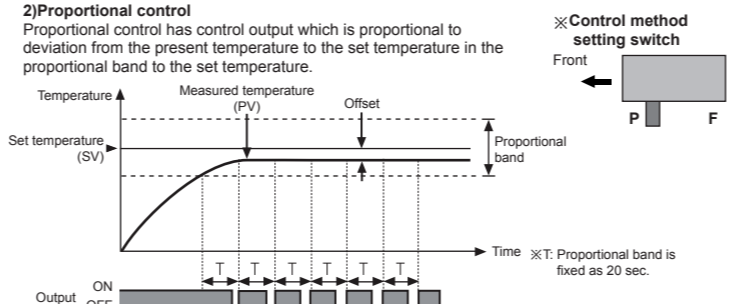
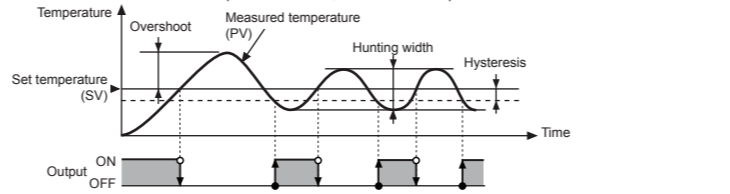

- It is available to control without overshoot or hunting comparing ON/OFF control but it may cause offset. Correct the offset with the RESET volume switch.  
[Setting range of Proportional band] F.S. 1 to 10% (In case of T3S, F.S. 3% fixed)  
[Setting range of RESET] F.S. -3 to 3%
- 2) Alarm output**  
Alarm temperature is applied to the high/low-limit based on the set temperature. Alarm output operates deviation high/low-limit.  
[Setting range of Alarm temperature] F.S. 0 to 10%  
E.g.) When F.S. is 400°C and max. alarm temperature (F.S. 10%) is 40°C.  
When the set temperature is set as 100°C, alarm output operation range is 140°C to 60°C.

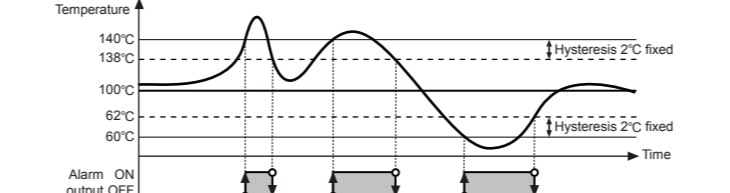

- 3) Sub output (Only for T3HS)**  
Only the T3HS model has sub output. This output operates as deviation low-limit alarm.  
[Setting range of Sub output] 0 to 50°C  
E.g.) Set temperature is set as 100°C and sub-output is set as 20°C

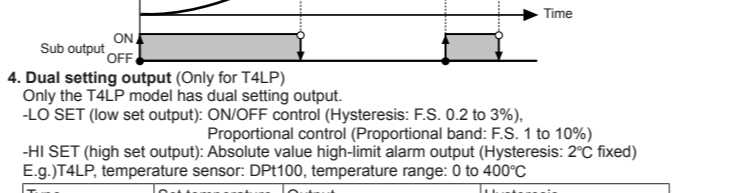

- 4) Dual setting output (Only for T4LP)**  
Only the T4LP model has dual setting output.  
-LO SET (low set output): ON/OFF control (Hysteresis: F.S. 0.2 to 3%)  
Proportional control (Proportional band: F.S. 1 to 10%)  
-HI SET (high set output): Absolute value high-limit alarm output (Hysteresis: 2°C fixed)  
E.g.) T4LP, temperature sensor: DP100, temperature range: 0 to 400°C

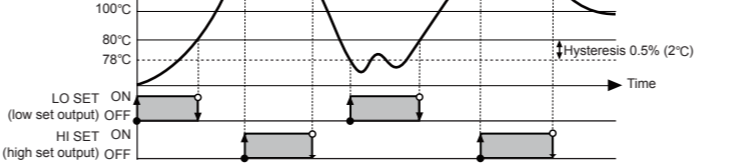

### Error Display And Output Operation

Display	Description	Control output <sup>※1</sup>	Alarm output <sup>※2</sup>	Sub output	Dual output	Troubleshooting
αPE n	Flashes when a temperature sensor is broken or not connected.	○	●	○	●	Check the status of the temperature sensor. When the sensor is connected correctly, it is clear.
HHHH	Flashes when the measured input value is higher than the temperature range of the sensor.	○	○	○	○	When the measured temperature is within the temperature range of the sensor, it is clear.
LLLL	Flashes when the measured input value is lower than the temperature range of the sensor.	○	○	○	○	When the measured temperature is within the temperature range of the sensor, it is clear.
SuE r	Flashes with the present value when the set value is out of the temperature range of the sensor.	○	○	○	○	The set value should be within the temperature range of the sensor.

※1: T4LP (Dual setting output) is the single output.  
 ※2: When SuE r and αPE n/HHHH/LLLL occur at the same time, SuE r and αPE n/HHHH/LLLL flash in turn and all output turns OFF.

### Dimensions

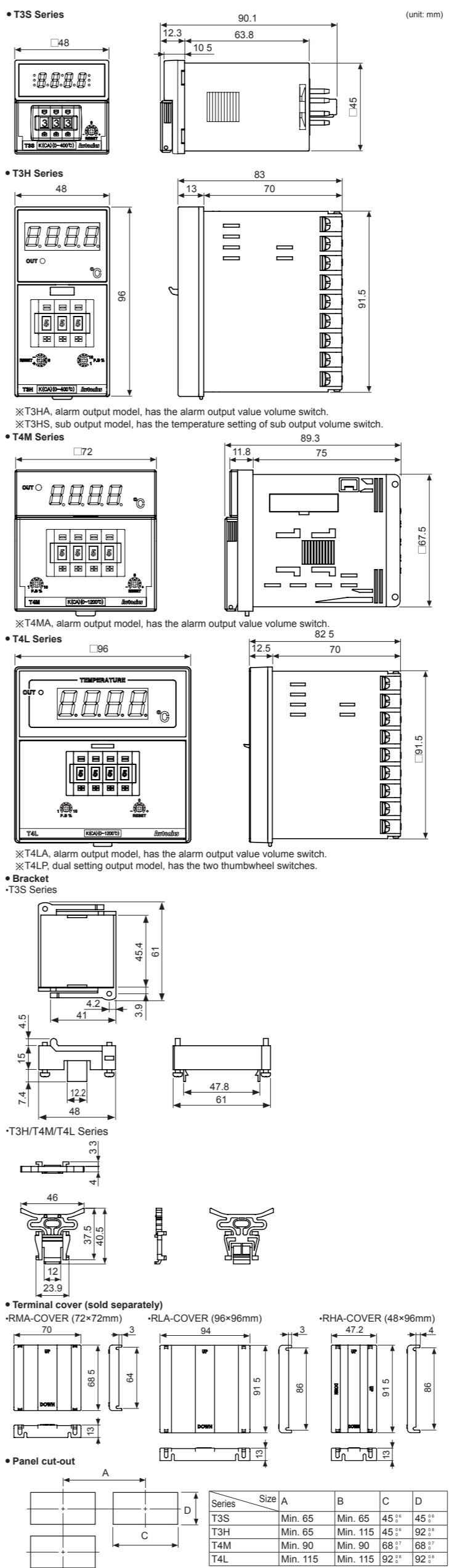

### Connection

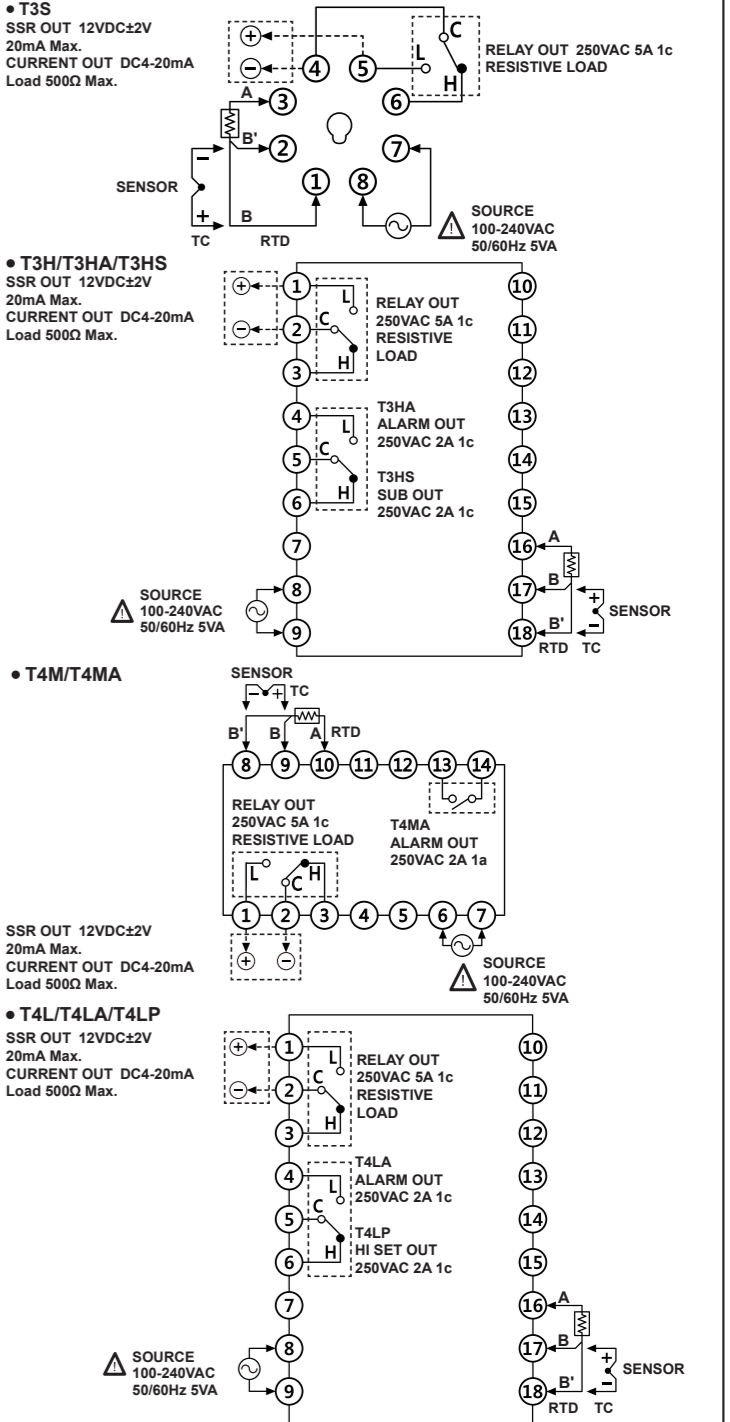

※Use terminals of size specified below.

Round	Forked
a Min. 3.5mm	a Min. 3.5mm
b Max. 7.2mm	b Max. 7.2mm

### Display When Power is ON

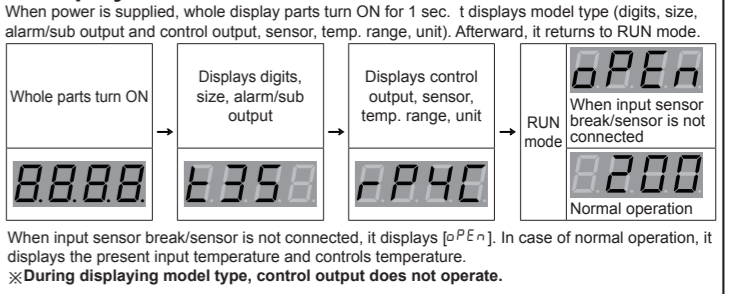

### Cautions during Use

- Follow instructions in 'Cautions during Use'. Otherwise, it may cause unexpected accidents.
- Check the polarity of the terminals before wiring the temperature sensor.
- For thermocouple (CT) temperature sensor, use the designated compensation wire for extending wire.
- Keep away from high voltage lines or power lines to prevent inductive noise.
- In case installing power line and input signal line closely, use line filter or varistor at power line and shielded wire at input signal line.
- Do not use near the equipment which generates strong magnetic force or high frequency noise.
- Install a power switch or circuit breaker in the easily accessible place for supplying or disconnecting the power.
- Do not use the unit for other purpose (e.g. voltmeter, ammeter), but temperature controller.
- Make a required space around the unit for radiation of heat.
- For accurate temperature measurement, warm up the unit over 20 min after turning on the power.
- Do not use the unit for other purpose (e.g. voltmeter, ammeter), but temperature controller.
- Do not wire to terminals which are not used.
- This unit may be used in the following environments.
  - Indoors (in the environment condition rated in 'Specifications')
  - Altitude max. 2,000m
  - Pollution degree 2
  - Installation category II

### Major Products

- Photoelectric Sensors
- Fiber Optic Sensors
- Door Sensors
- Door Side Sensors
- Area Sensors
- Proximity Sensors
- Pressure Sensors
- Rotary Encoders
- Connector/Sockets
- Switching Mode Power Supplies
- Control Switches/Lamps/Buzzers
- IO Terminal Blocks & Cables
- Stepper Motors/Drivers/Motion Controllers
- Field Network Devices
- Laser Marking System (Fiber, Co., Nd:YAG)
- Laser Welding/Cutting System
- Temperature Controllers
- Temperature/Humidity Transducers
- SSR/Power Controllers
- Counters
- Timers
- Temperature Meters
- Tachometer/Pulse (Rate) Meters
- Display Units
- Sensor Controllers